

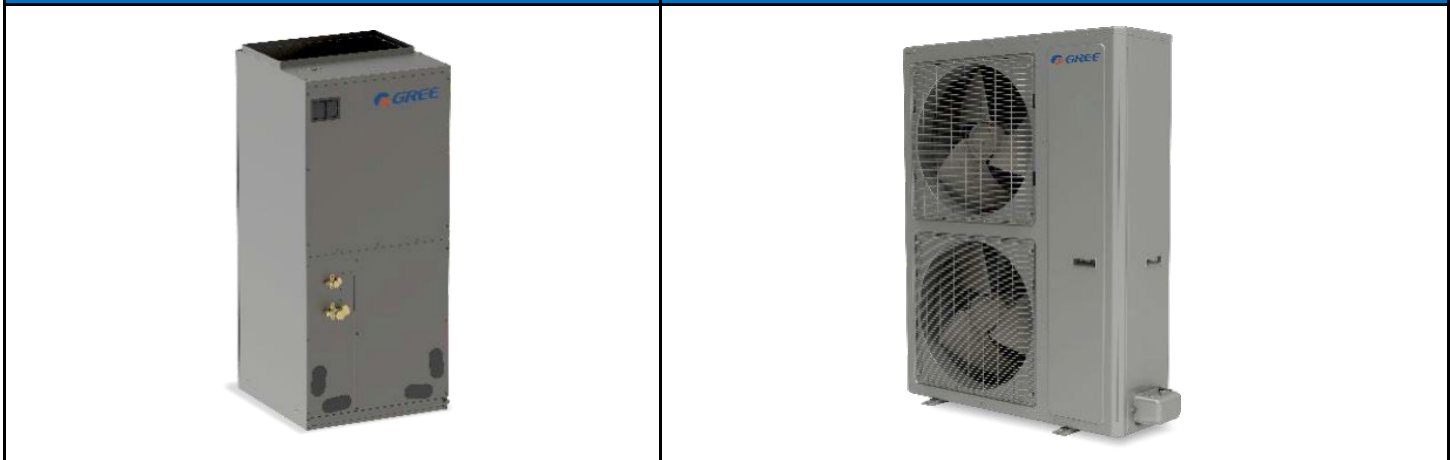

SUBMITTAL DATA: GUD60AH2/A-D(U) / GUD60W/A-D(U) 60000 BTU/H Unitary Heat Pump Split System

Job Name	Location	Date
Purchaser	Engineer	
Submitted To	For	
Unit Designation	Schedule No.	

GUD60AH2/A-D(U)	GUD60W/A-D(U)
------------------------	----------------------



GENERAL FEATURES

High Efficiency DC Inverter Technology

Compact and Quiet 55 dB(A) Side Discharge Outdoor Unit Zero Lot Line Design

Match with Gree or Competitive Indoor Unit

Designed for New Construction or Replacement Market 24VAC Thermostat Compatible

Constant Flow Air Handler With 8 Selectable Fan Speeds Condensing Unit Field Convertible to 4.0 Ton

Low Ambient Cooling down to 0°F

Low Ambient Heating down to -22°F

Acrylic Resin/Anti-Corrosion Fin Coating (Blue - 500 Hr Salt Spray Rating)

10 Year Unlimited Parts Warranty

SPECIFICATIONS

GUD60AH2/A-D(U) / GUD60W/A-D(U)

System Type		HEAT PUMP AHRI - 206249118	
SYSTEM PERFORMANCE			
Cooling	Rated Capacity @ 95°F	Btu/h	54000
	Min-Max Capacity	Btu/h	35000 - 54000
Heating	Rated Capacity @ 47°F	Btu/h	54000
	Rated Capacity @ 17°F	Btu/h	38000
	Min-Max Capacity	Btu/h	35000 - 60000
SEER / EER		17 / 10.5	
HSPF / COP		10 / 3.45	
Energy Star®		NO	
Cooling Temperature Range		°F	0 - 129
Heating Temperature Range		°F	-22 - 75
INDOOR UNIT			
Fan Motor Output Power		W	746
Fan Motor FLA		amps	5
Air Flow (Min - Max)		CFM	1600
Static Pressure (Rated / Maximum)		In w.c	0.2 / 1.0
Sound Pressure Level (Cooling / Heating)		dB(A)	51
Dehumidification		pt/hr	12.13
Condensate Drain Size (OD)		in	3 / 4
Unit Dimension (WxHxD)		in	24 3/4 x 57 x 21 1/4
Package Dimension (WxHxD)		in	27 5/16 x 59 3/8 x 26
Weight (Net / Gross)		lbs	202 / 218
Electric Heater (Optional)		kW	10, 15, 20
OUTDOOR UNIT			
Compressor Type		Inverter Rotary	
Compressor RLA		amps	19
Fan Motor Output Power (2)		W	149 Ea
Fan Motor (2)		amps	1.5 Ea
Sound Pressure Level (Cooling / Heating)		dB(A)	58
Unit Dimension (WxHxD)		in	39 3/8 x 53 5/8 x 14 1/2
Package Dimension (WxHxD)		in	45 7/16 x 59 1/4 x 19 7/16
Weight (Net / Gross)		lbs	308 / 337
Refrigerant Charge - R410A		oz	220.5
Coil Type (Blue Fin)		Copper Tube / Aluminum Fin	
REFRIGERANT PIPING			
Line Set Size (Liquid - Gas)		in	3/8 - 3/4
Pre-Charge Length		ft	31
Additional Charge		oz/ft	0.32
Pipe Length (Min - Max)		ft	10 - 100
Max. Pipe Elevation		ft	50
ELECTRICAL			
Power Supply (Voltage Operating Range)		208/230V / 1Ph / 60 Hz	
Outdoor Unit	Rated Current (Cooling / Heating)	amps	30 / 31
	MCA / MOCP	amps	35 / 45
Indoor Unit	Rated Current (Cooling / Heating)	amps	5 / 5
	MCA / MOCP	amps	8 / 15
Main Power Wire Size		AWG	Size Per Local Code

FAN PERFORMANCE

GUD60AH2/A-D(U)

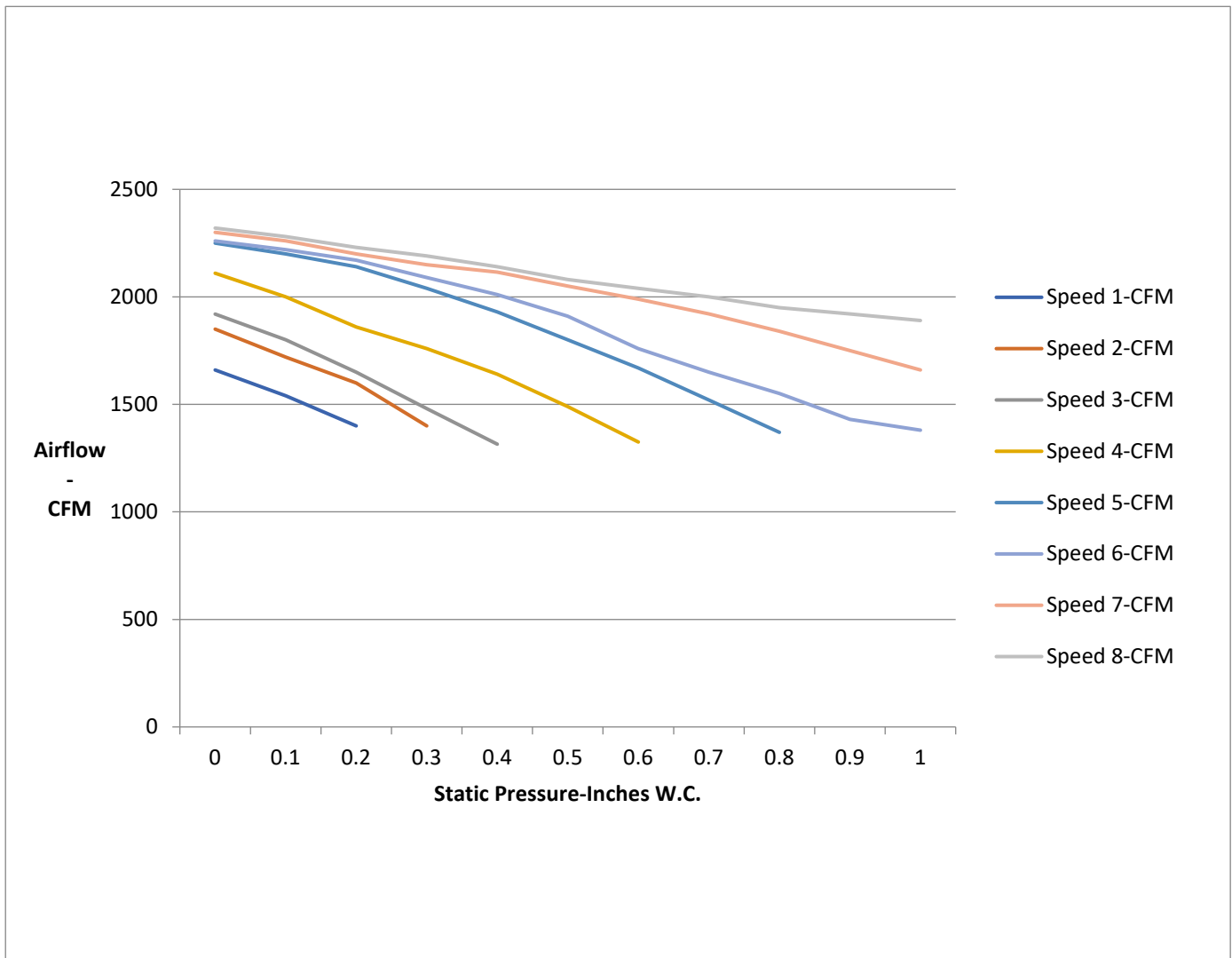

Static Pressure- Inches W.C.	0	0.1	0.15	0.2	0.3	0.4	0.5	0.6	0.7	0.8	0.9	1.0
Speed 1-CFM	1660	1540	1470	1400								
Speed 2-CFM	1850	1720	1650	1600	1400							
Speed 3-CFM	1920	1800	1730	1650	1480	1315						
Speed 4-CFM	2110	2000	1950	1860	1760	1640	1490	1325				
Speed 5-CFM	2250	2200	2190	2140	2040	1930	1800	1670	1520	1370		
Speed 6-CFM	2260	2220	2200	2170	2090	2010	1910	1760	1650	1550	1430	1380
Speed 7-CFM	2300	2260	2230	2200	2150	2115	2050	1990	1920	1840	1750	1660
Speed 8-CFM	2320	2280	2250	2230	2190	2140	2080	2040	2000	1950	1920	1890

EXTENDED RATINGS

GUD60AH2/A-D(U) / GUD60W/A-D(U)

COOLING PERFORMANCE						HEATING PERFORMANCE				
Outdoor Ambient Temperature (DB)		Return Air Temperature				Outdoor Ambient Temperature (DB)		Return Air Temperature		
		80°F (DB)						70°F (DB)		
		TC (Btu/h)	SHR	EER	Power Input (W)			TC (Btu/h)	COP	Power Input (W)
MAX OUTPUT	5°F	54000	68.5%	14.8	3650	MAX OUTPUT	-22°F	27000	1.25	6350
	10°F	54000	70.8%	14.6	3700		-20°F	29000	1.31	6500
	15°F	54000	70.0%	14.4	3750		-15°F	32000	1.40	6700
	20°F	54000	71.0%	14.2	3800		-10°F	34000	1.45	6900
	25°F	54000	71.6%	14.1	3830		-5°F	37000	1.55	7000
	30°F	54000	69.8%	13.9	3880		0°F	40000	1.65	7100
	35°F	54000	70.9%	13.7	3950		5°F	44000	1.80	7160
	40°F	54000	69.5%	13.4	4020		10°F	46000	1.89	7140
	45°F	54000	71.2%	13.2	4080		15°F	48000	1.98	7120
	50°F	54000	70.0%	13.1	4120		17°F	49000	2.02	7100
	55°F	54000	70.8%	13.0	4160		20°F	50000	2.13	6900
	60°F	54000	71.0%	12.9	4200		25°F	52000	2.26	6750
	65°F	54000	70.0%	12.7	4250		30°F	54000	2.38	6650
	70°F	54000	71.5%	12.5	4330		35°F	54000	2.47	6400
	75°F	54000	69.8%	12.3	4400		40°F	54000	2.64	6000
	80°F	54000	70.4%	12.0	4500		45°F	54000	2.83	5600
	85°F	55000	69.5%	11.8	4650		47°F	56000	3.10	5300
	90°F	55000	71.7%	11.0	5000		50°F	58000	3.18	5350
	95°F	55000	70.0%	10.2	5410		55°F	58000	3.20	5320
	100°F	55000	70.8%	9.2	6000		60°F	60000	3.26	5400
	105°F	54000	69.0%	8.1	6650		65°F	60000	3.38	5200
	110°F	50000	70.9%	8.1	6180		70°F	60000	3.52	5000
	115°F	46000	71.0%	8.1	5700		75°F	54000	4.17	3800
	120°F	38000	68.7%	7.6	5000					
125°F	32000	67.6%	6.8	4700						
129°F	28000	71.0%	6.3	4450						

LEGEND: W - Watts
 DB - Dry Bulb
 TC - Total Capacity
 SHR - Sensible Heat Ratio
 COP - Coefficient of Performance

FEATURES SUMMARY**GUD60AH2/A-D(U)/ GUD60W/A-D(U)**

SYSTEM FEATURES	
Compressor	Inverter
Ultra Low Frequency Torque Control	YES
Power Factor Correction	YES
Compressor Type	Rotary
Refrigerant Type	R410A
Outdoor Electronic Expansion Valve (EEV)	YES
Indoor TXV Control	YES
Basepan With Electric Heater	YES
Compressor With Electric Heater	YES
Fin Coating (Outdoor & Indoor)	Acrylic Resin
Intelligent Defrosting	YES
Intelligent Preheating	YES
Low Voltage Startup	YES
Memory/Power Failure Recovery	YES
Self Diagnosis	YES
Low Ambient Cooling	YES
24VAC Thermostat Compatible	YES
Indoor Fan Type	Centrifugal
Multi Fan Speeds	8 Speeds
Auxiliary Electrical Heater	Optional

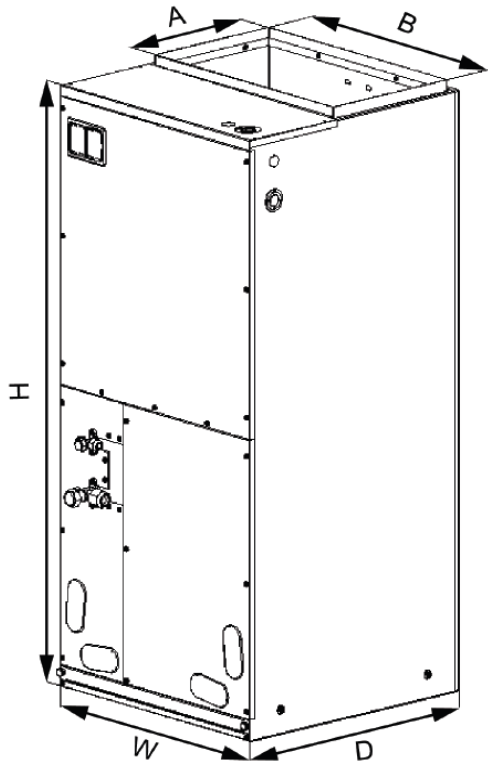

Dimensions	
A	11 5/8
B	20
H	57
W	24 3/4
D	21 1/4

Filter Size	
Supplied*	20 5/8 x 20 5/16 x 1/2
Suggested	20 5/8 x 20 5/16 x 1

*Supplied filter is metal mesh

Clearances	
Front	> 24

Allow a minimum of 24" in front of the unit for service clearance. When installing in an area directly over a finished ceiling (such as an attic), an emergency drain pan is required directly under the unit. **See local and state codes for requirements.** When installing this unit in an area that may become wet, elevate the unit with a sturdy, non-porous material. In installations that may lead to physical damage (i.e. a garage) it is advised to install a protective barrier to prevent such damage.

This air handler is designed for a complete supply and return ductwork system.

Multi-Position Capabilities

Top & Horizontal (Left/Right) Flow Only

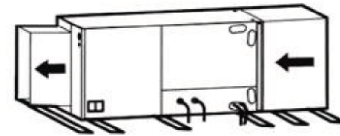
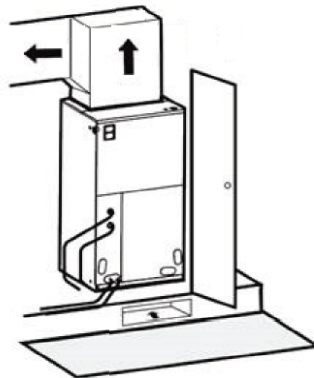

Horizontal Left Configuration - No Modification Needed

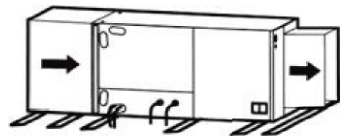

Horizontal Right Configuration - Must Relocate Drain Pan

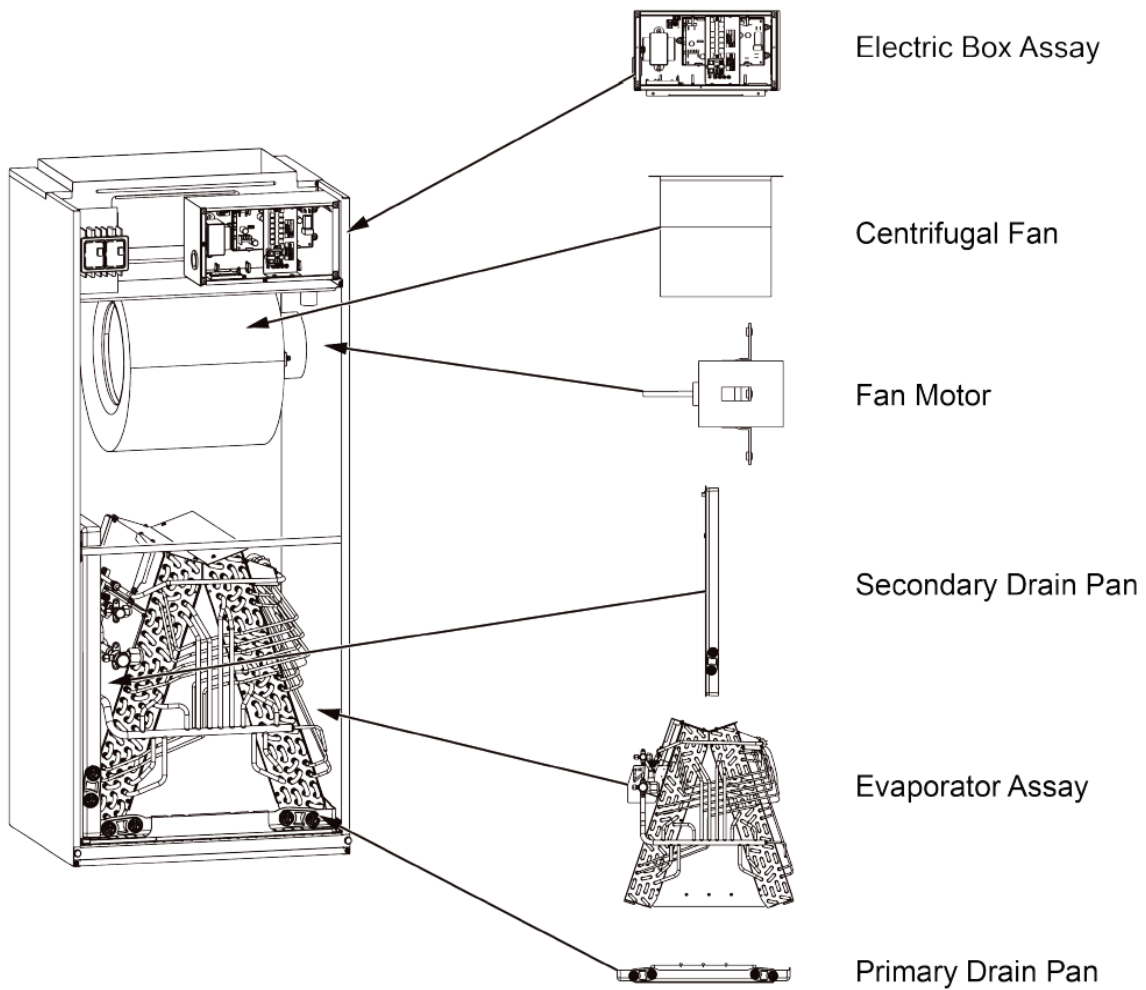

Model	Heat Kit Model	Electric Heat (kW)		Min. Circuit		Max.Fuse or Breaker	
		240V	208V	240V	208V	240V	208V
GUD60AH2/A-D(U)							
	21-4216-01	10	7.51	52	45	60	45
	21-4217-00	15	11.25	52 & 26	45 & 22.6	60 & 30	45 & 25
	21-4228-00	20	15.02	52 & 52	45 & 45	60 & 60	45 & 45



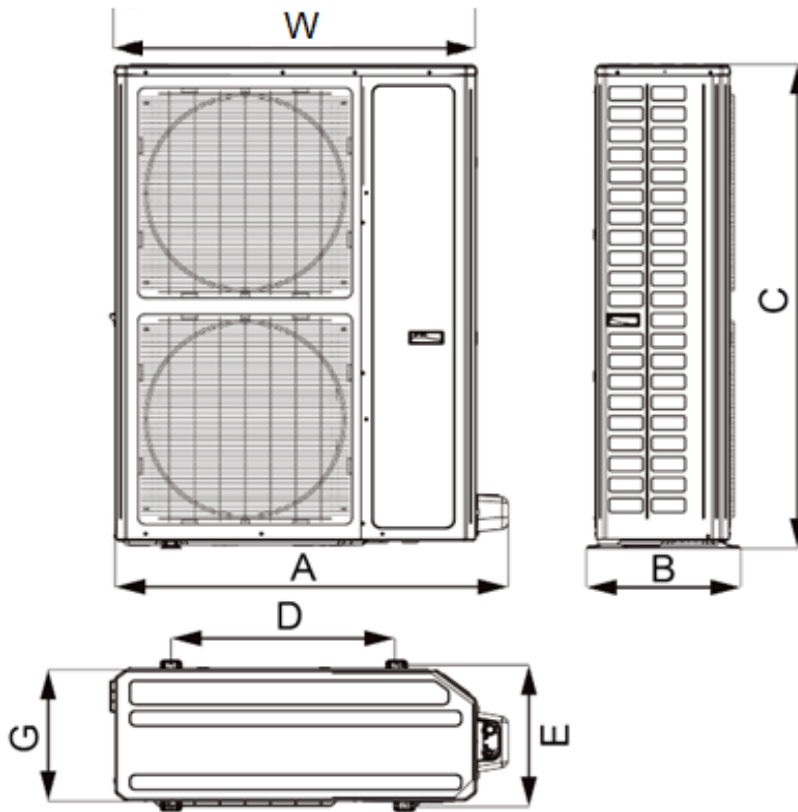

Dimensions	
A	42 3/4
B	16 7/8
C	53 5/8
D	24 3/8
E	15 5/8
G	14 1/2
W	39 3/8

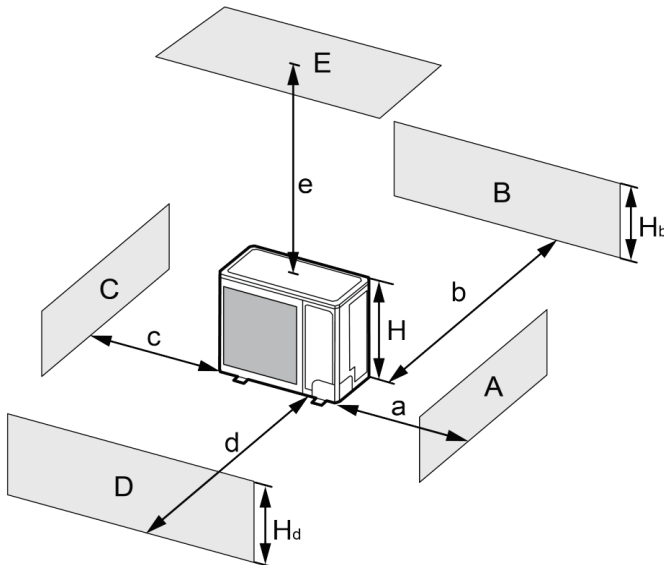

A-E	H _b	H _d	H	(in)				
				a	b	c	d	e
B	—	—	—	-	≥ 4	-	-	-
A,B,C	—	—	—	≥ 12	≥ 4	≥ 4	-	-
B,E	—	—	—	-	≥ 4	-	-	≥ 40
A,B,C,E	—	—	—	≥ 12	≥ 6	≥ 6	-	≥ 40
D	—	—	—	-	-	-	≥ 40	-
D,E	—	—	—	-	-	-	≥ 40	≥ 40
B,D	H _b < H _d	H _d > H	-	≥ 4	-	≥ 40	-	-
	H _b > H _d	H _d < H	-	≥ 4	-	≥ 40	-	-
B,D,E	H _b < H _d	H _d ≤ 1/2H	-	≥ 10	-	≥ 80	≥ 40	-
		1/2H < H _d ≤ H	-	≥ 10	-	≥ 80	≥ 40	-
	H _b > H	Prohibited					-	-
	H _b > H _d	H _d ≤ 1/2H	-	≥ 4	-	≥ 80	≥ 40	-
		1/2H < H _d ≤ H	-	≥ 8	-	≥ 80	≥ 40	-
H _d > H	Prohibited					-	-	