





SUBMITTAL DATA: GUD36AH2/A-D(U) / GUD36W/A-D(U)

Job Number	Location	Date
Purchaser	Engineer	
Submitted To	For	
Unit Designation	Schedule No.	

GUD36AH2/A-D(U)	GUD36W/A-D(U)
	
GENERAL FEATURES	

High Efficiency DC Inverter Technology

Compact and Quiet 52 dB(A) Side Discharge Outdoor Unit

Zero Lot Line Design

Match with Gree or Competitive Indoor Unit

Designed for New Construction or Replacement Market 24VAC Thermostat Compatible

Constant CFM Air Handler With 8 Selectable Fan Speeds

Low Ambient Cooling down to 0°F

Low Ambient Heating down to -22°F

Acrylic Resin/Anti-Corrosion Fin Coating (Blue - 500 Hr Salt Spray Rating)

10 Year Unlimited Parts Warranty

SPECIFICATIONS		GUD36AH2/A-D(U) / GUD36W/A-D(U)	
System Type		HEAT PUMP AHRI - 206249117	
SYSTEM PERFORMANCE			
Cooling	Rated Capacity @ 95°F	Btu/h	36000
	Min-Max Capacity	Btu/h	18000 - 37000
Heating	Rated Capacity @ 47°F	Btu/h	36000
	Rated Capacity @ 17°F	Btu/h	24400
	Min-Max Capacity	Btu/h	18000 - 38000
SEER / EER		18 / 11	
HSPF / COP		10 / 3.5	
Energy Star®		NO	
Cooling Temperature Range		°F	5 - 129
Heating Temperature Range		°F	-22 - 75
INDOOR UNIT			
Fan Motor Output Power		W	373
Fan Motor FLA		amps	3
Air Flow (Min - Max)		CFM	1000
Static Pressure (Rated / Maximum)		In w.c	0.15 / 1.0
Sound Pressure Level (Cooling / Heating)		dB(A)	47
Dehumidification		pt/hr	9.68
Condensate Drain Size (OD)		in	3 / 4
Unit Dimension (WxHxD)		in	21 1/4 x 48 1/4 x 21 1/4
Package Dimension (WxHxD)		in	26 x 50 7/16 x 23 3/4
Weight (Net / Gross)		lbs	156 / 169
Electric Heater (Optional)		kW	8, 10, 15
OUTDOOR UNIT			
Compressor Type		Inverter Rotary	
Compressor RLA		amps	16
Fan Motor Output Power		W	149
Fan Motor		amps	1.5
Sound Pressure Level (Cooling / Heating)		dB(A)	52 (45~57) *
Unit Dimension (WxHxD)		in	32 1/4 x 37 x 18 1/8
Package Dimension (WxHxD)		in	38 3/8 x 42 11/16 x 22 9/16
Weight (Net / Gross)		lbs	217 / 240
Refrigerant Charge - R410A		oz	148
Coil Type (Blue Fin)		Copper Tube / Aluminum Fin	
REFRIGERANT PIPING			
Line Set Size (Liquid - Gas)		in	3/8 - 3/4
Pre-Charge Length		ft	31
Additional Charge		oz/ft	0.32
Pipe Length (Min - Max)		ft	10 - 100
Max. Pipe Elevation		ft	50
ELECTRICAL			
Power Supply (Voltage Operating Range)		208/230V / 1Ph / 60 Hz	
Outdoor Unit	Rated Current (Cooling / Heating)	amps	21 / 25
	MCA / MOCP	amps	24 / 35
Indoor Unit	Rated Current (Cooling / Heating)	amps	3 / 3
	MCA / MOCP	amps	4 / 15
Main Power Wire Size		AWG	Size Per Local Code

* Average (minimum ~ maximum)

FAN PERFORMANCE

GUD36AH2/A-D(U)

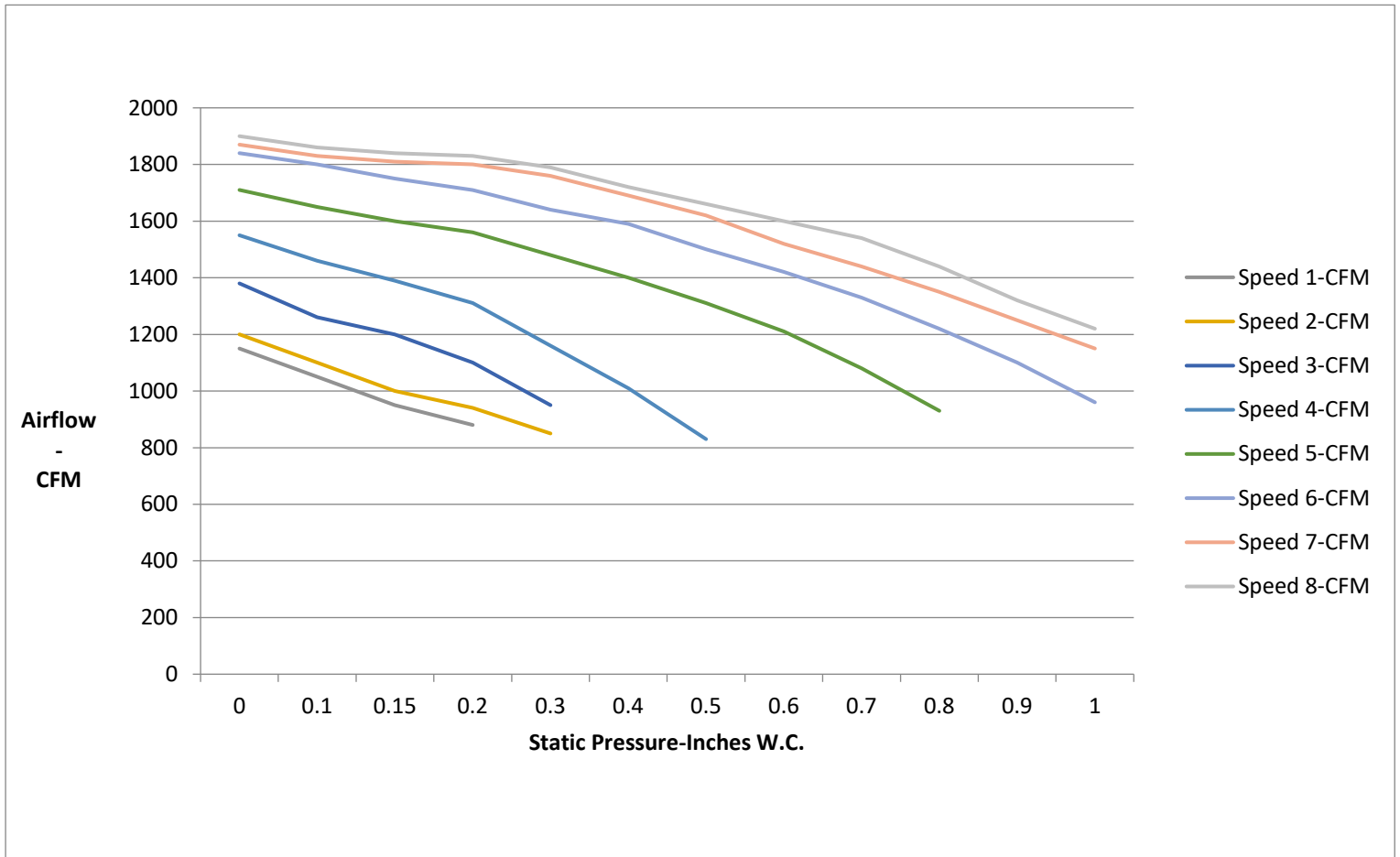

Static Pressure Inches W.C.	0	0.1	0.15	0.2	0.3	0.4	0.5	0.6	0.7	0.8	0.9	1.0
Speed 1-CFM	1150	1050	950	880								
Speed 2-CFM	1200	1100	1000	940	850							
Speed 3-CFM	1380	1260	1200	1100	950							
Speed 4-CFM	1550	1460	1390	1310	1160	1010	830					
Speed 5-CFM	1710	1650	1600	1560	1480	1400	1310	1210	1080	930		
Speed 6-CFM	1840	1800	1750	1710	1640	1590	1500	1420	1330	1220	1100	960
Speed 7-CFM	1870	1830	1810	1800	1760	1690	1620	1520	1440	1350	1250	1150
Speed 8-CFM	1900	1860	1840	1830	1790	1720	1660	1600	1540	1440	1320	1220

EXTENDED RATINGS

GUD36AH2/A-D(U) / GUD36W/A-D(U)

COOLING PERFORMANCE						HEATING PERFORMANCE				
Outdoor Ambient Temperature (DB)		Return Air Temperature				Outdoor Ambient Temperature (DB)		Return Air Temperature		
		80°F (DB)						70°F (DB)		
		TC (Btu/h)	SHR	EER	Power Input (W)			TC (Btu/h)	COP	Power Input (W)
MAX OUTPUT	5°F	36000	68.5%	16.29	2210	MAX OUTPUT	-22°F	18400	1.30	4150
	10°F	36000	70.8%	16.00	2250		-20°F	20000	1.38	4250
	15°F	36000	70.0%	15.79	2280		-15°F	21100	1.40	4430
	20°F	36000	71.0%	15.75	2285		-10°F	23500	1.50	4580
	25°F	36000	71.6%	15.69	2295		-5°F	25200	1.60	4630
	30°F	36000	69.8%	15.65	2300		0°F	28000	1.75	4700
	35°F	36000	70.9%	15.32	2350		5°F	30000	1.83	4800
	40°F	36000	69.5%	15.00	2400		10°F	31500	1.85	5000
	45°F	36000	71.2%	14.69	2450		15°F	34000	1.92	5200
	50°F	36000	70.0%	14.40	2500		17°F	36000	1.94	5450
	55°F	36000	70.8%	14.23	2530		20°F	36000	2.05	5150
	60°F	36000	71.0%	14.01	2570		25°F	36000	2.11	5000
	65°F	36000	70.0%	13.85	2600		30°F	36000	2.18	4850
	70°F	36000	71.5%	13.58	2650		35°F	36000	2.30	4600
	75°F	36000	69.8%	13.33	2700		40°F	36000	2.51	4200
	80°F	36000	70.4%	12.41	2900		45°F	37000	2.71	4000
	85°F	37000	69.5%	11.94	3100		47°F	38000	3.10	3600
	90°F	37000	71.7%	11.21	3300		50°F	38000	3.18	3500
	95°F	37000	70.0%	10.28	3600		55°F	38000	3.38	3300
	100°F	36000	70.8%	9.00	4000		60°F	38000	3.54	3150
	105°F	36000	69.0%	8.18	4400		65°F	38000	3.57	3120
110°F	35000	70.9%	8.14	4300	70°F	38000	3.58	3115		
115°F	33000	71.0%	8.05	4100	75°F	36000	3.58	2950		
120°F	30000	68.7%	7.89	3800						
125°F	25000	67.6%	7.81	3200						
129°F	23000	71.0%	7.67	3000						

- LEGEND:** W - Watts
 DB - Dry Bulb
 TC - Total Capacity
 SHR - Sensible Heat Ratio
 COP - Coefficient of Performance
 TC - Total Capacity
 SHR - Sensible Heat Ratio
 COP - Coefficient of Performance

FEATURES SUMMARY

GUD36AH2/A-D(U) / GUD36W/A-D(U)

SYSTEM FEATURES	
Compressor	Inverter
Ultra Low Frequency Torque Control	YES
Power Factor Correction	YES
Compressor Type	Rotary
Refrigerant Type	R410A
Outdoor Electronic Expansion Valve (EEV)	YES
Indoor TXV Control	YES
Basepan With Electric Heater	YES
Compressor With Electric Heater	YES
Fin Coating (Outdoor & Indoor)	Acrylic Resin
Intelligent Defrosting	YES
Intelligent Preheating	YES
Low Voltage Startup	YES
Memory/Power Failure Recovery	YES
Self Diagnosis	YES
Low Ambient Cooling	YES
24VAC Thermostat Compatible	YES
Indoor Fan Type	Centrifugal
Multi Fan Speeds	8 Speeds
Auxiliary Electrical Heater	Optional

DIMENSIONS & CLEARANCES

GUD36AH2/A-D(U)

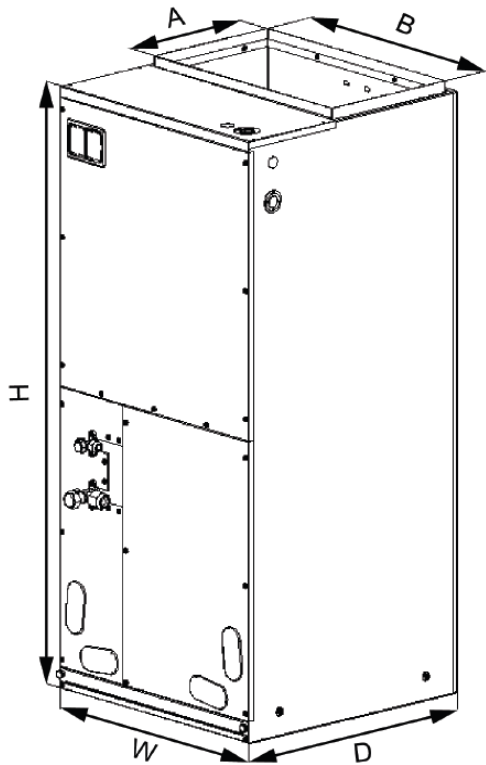

Dimensions	
A	11 5/8
B	20
H	48 1/4
W	21 1/4
D	21 1/4

Filter Size	
Supplied*	19 1/4 x 20 1/4 x 1/2
Suggested	19 1/4 x 20 1/4 x 1

*Supplied filter is metal mesh

Clearances	
Front	> 24

Allow a minimum of 24" in front of the unit for service clearance. When installing in an area directly over a finished ceiling (such as an attic), an emergency drain pan is required directly under the unit. **See local and state codes for requirements.** When installing this unit in an area that may become wet, elevate the unit with a sturdy, non-porous material. In installations that may lead to physical damage (i.e. a garage) it is advised to install a protective barrier to prevent such damage.

This air handler is designed for a complete supply and return ductwork system.

Multi-Position Capabilities

Top & Horizontal (Left/Right) Flow Only

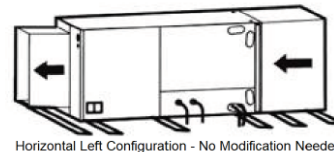
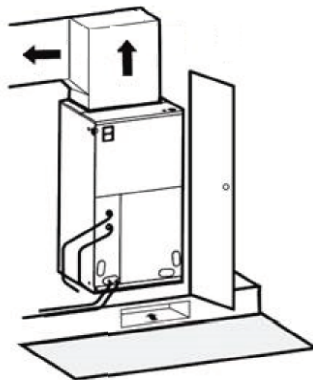

Horizontal Left Configuration - No Modification Needed

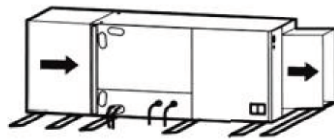

Horizontal Right Configuration - Must Relocate Drain Pan

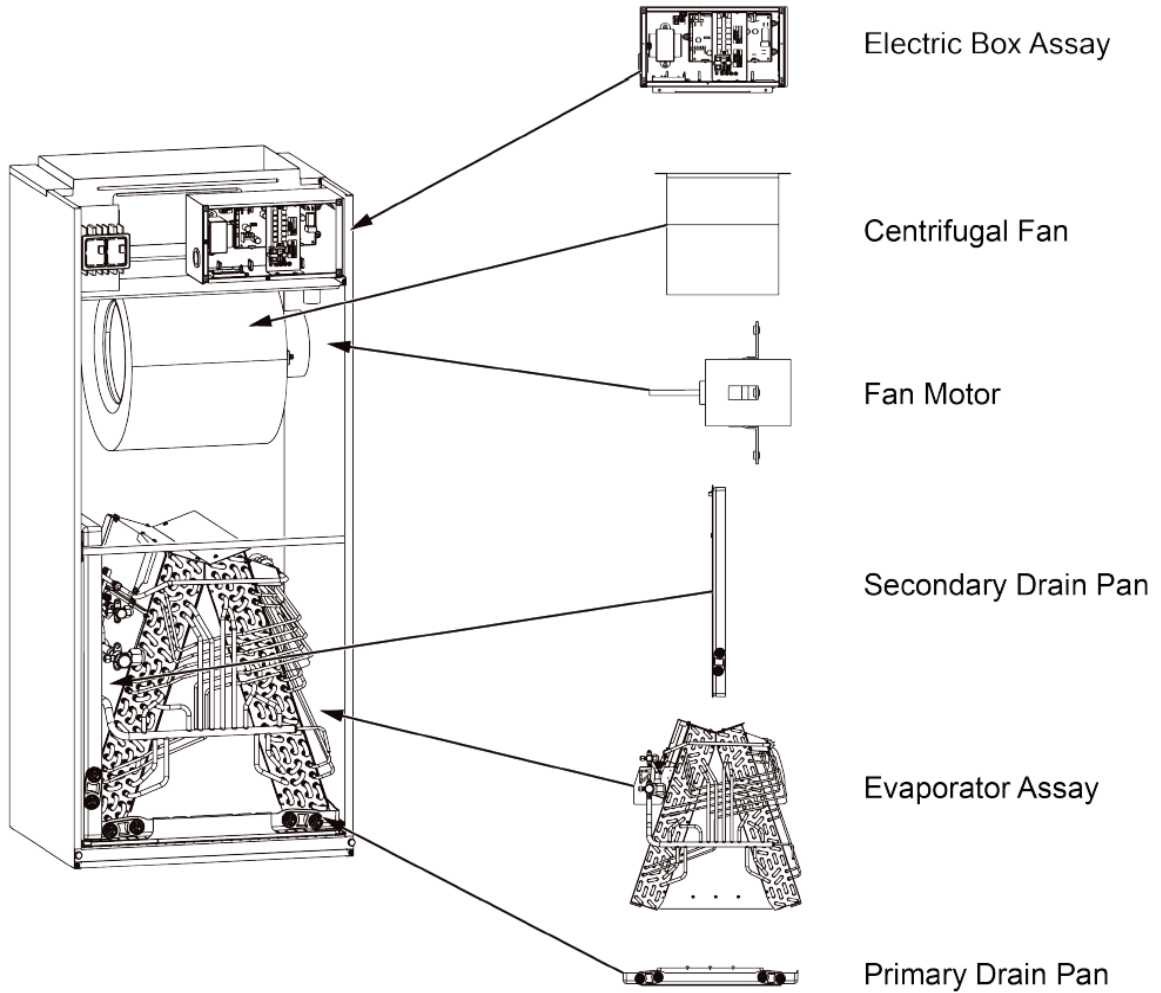

Model	Heat Kit Model	Electric Heat (kW)		Min. Circuit Ampacity Heater Only		Max.Fuse or Breaker Ampacity Heater Only	
		240V	208V	240V	208V	240V	208V
GUD36AH2/A-D(U)							
	21-4227-00	5	3.76	26	22.6	30	25
	21-4216-00	8	6	41.7	36	45	40
	21-4216-01	10	7.51	52	45	60	45



DIMENSIONS & CLEARANCES

GUD36W/A-D(U)

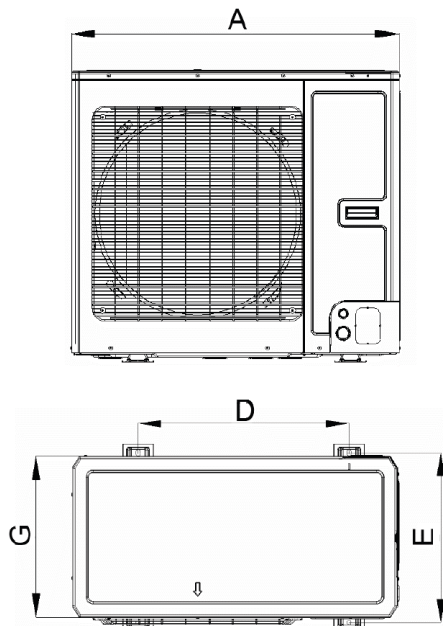

Dimensions	
A	37
B	20 1/8
C	32 1/4
D	24
E	19 1/8
G	18 1/8

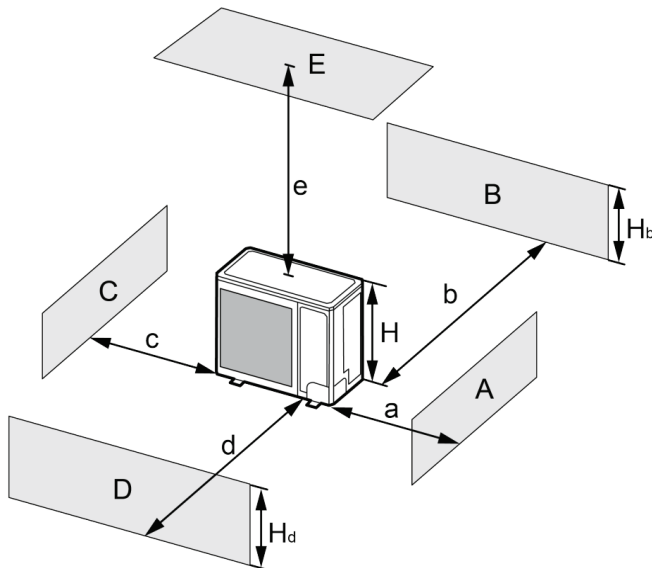

A-E	H _b	H _d	H	(in)				
				a	b	c	d	e
B	—	—	—	-	≥ 4	-	-	-
A,B,C	—	—	—	≥ 12	≥ 4	≥ 4	-	-
B,E	—	—	—	-	≥ 4	-	-	≥ 40
A,B,C,E	—	—	—	≥ 12	≥ 6	≥ 6	-	≥ 40
D	—	—	—	-	-	-	≥ 40	-
D,E	—	—	—	-	-	-	≥ 40	≥ 40
B,D	H _b < H _d	H _d > H	—	≥ 4	-	≥ 40	-	-
	H _b > H _d	H _d < H	-	≥ 4	-	≥ 40	-	-
B,D,E	H _b < H _d	H _b ≤ 1/2H	-	≥ 10	-	≥ 80	≥ 40	≥ 40
		1/2H < H _b ≤ H	-	≥ 10	-	≥ 80	≥ 40	≥ 40
	H _b > H	Prohibited						
	H _b > H _d	H _d ≤ 1/2H	-	≥ 4	-	≥ 80	≥ 40	≥ 40
		1/2H < H _d ≤ H	-	≥ 8	-	≥ 80	≥ 40	≥ 40
		H _d > H	Prohibited					

Specifications are subject to change without notice. Manufacturer reserves the right to discontinue or modify specifications or designs without notice or without incurring obligations. All Rights reserved.